

CNC Coiling and Bending Machine for the Production of Two- and Three-Dimensionally Bent Parts and Frames from Wire and Profiled Materials



B 36 *Performance*

B 36 Performance

▼ Two options for bend-back clearance (400 or 800 mm)

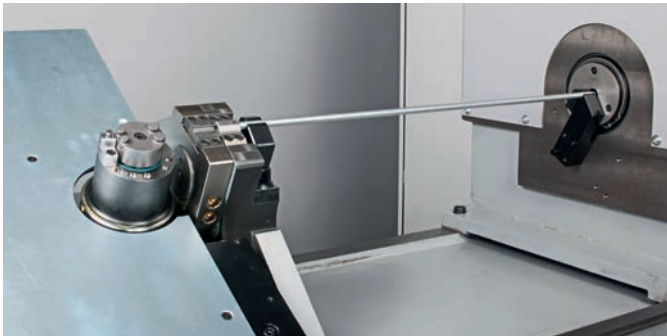

▼ Infeed including straightening unit

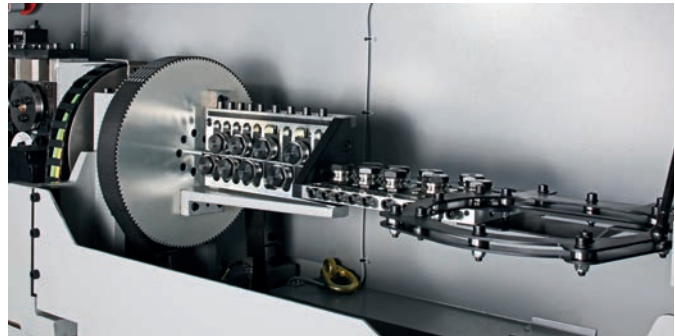

Our Accomplishments for your Benefit

- Performance machines are built on the basis of many years of WAFIOS know-how
- Application-oriented standard equipment based on solid and reliable technology - Performance machines have been designed for the most common wire bending applications
- Defined number of options - In contrast to High-Performance machines, there is a limited number of options available
- WAFIOS WPS 3.2 EasyWay high-end programming system
- Modern operating concept based on the one used by the High-Performance machines of the B, BM and BMU series

Design Features

- Basic machine with 5 CNC axes (standard) upgradable to a maximum of 6 CNC axes
- Robust infeed unit for advancing and rotating the wire together with the roller straightening unit, it can be displaced manually in order to adjust the bend-back clearance
- Diverse bending tools with large bending clearance and flexible application possibilities thanks to the infinitely rotating bending and mandrel axes as well as vertical strokes
- Defined number of options, e.g. CNC-controlled support table to support bent parts and prevent unwanted deformations or the guide wheel, which prevents wire from twisting during wire feed

High-End Programming System

- User-friendly machine operation with WAFIOS' latest WPS 3.2 EasyWay programming system with plain-text programming of lengths, angles or coordinates
- Connection to all machine components and graphic user interfaces
- Control panel carriage with a touchscreen display and hand-held operating device

▼ Control panel with new hand-held operating device



Safe, Efficient and Profitable – WAFIOS B 36 *Performance* CNC Coiling and Bending Maschine

Performance – The New Definition of Flexibility

WAFIOS *Performance* Machines are characterized by optimized basic equipment and by a defined selection of options. The machines are based on decades of WAFIOS engineering know-how. All *Performance* machines are equipped with the High-End WAFIOS WPS 3.2 EasyWay programming system. All these features result in high outputs and high machine availability.

On the WAFIOS B 36 *Performance*, there are two options to adjust the distance between feed unit and bending head. Therefore, the machines feature very reliable bending and coiling parameters that enable a wide range of possible applications.

The standard equipment of the machines includes 5 CNC axes. The machines can optionally be equipped with an additional support plate (1 CNC axis). This plate can be used to produce large frame parts in the 3D bending mode. The machine design engineered by WAFIOS with rotating infeed unit and fixed bending head guarantees highest production output while maintaining outstanding quality.



▲ Standard 4-pin bending tool

Quality

For more than 130 years, the name of WAFIOS has been synonymous with highest quality, safety standards, and technical innovations in the German machine manufacturing industry.

Reliability

Strict quality controls, state-of-the-art production systems, and many years of experience guarantee that your investment is safe in our hands. Our global service network ensures high availability of WAFIOS machinery.

Cost efficiency

High production output and a long service life will save money and shorten the amortization time of your investment.

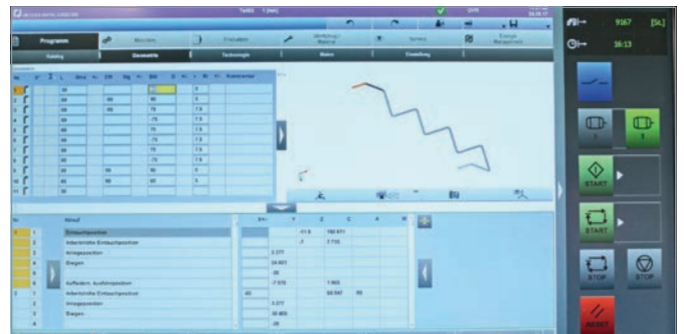

▲ Userfriendly WAFIOS Programming System WPS 3.2 EasyWay

Technical data	B 36 Performance
Operating range, wire Ø: <div style="margin-left: 20px;"> $< 600 \text{ N/mm}^2$ $< 1.200 \text{ N/mm}^2$ $< 1.900 \text{ N/mm}^2$ </div>	<div style="margin-left: 20px;"> 2.0 – 6.5 mm 2.0 – 4.5 mm 2.0 – 3.6 mm </div>
Feed rollers	2 pairs
Rotary angle, mandrel axis	Infinite
Rotary angle, bending axis	Infinite
Bending head, up/down travel	+5 / –20 mm
Bend-back clearance	400 / 800 mm
Bending head positioning	+30° fixed
Travel of CNC support table (option)	+25 / –200 mm
Feed speed	max. 120 m/min
Bending torque	ca. 180 Nm
Number of standard CNC axes	5 (6 option)

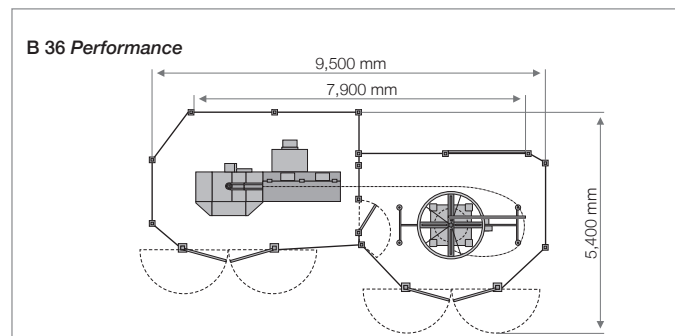
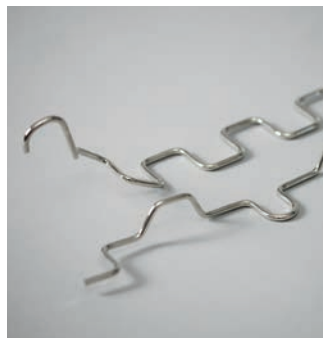

WAFIOS AG

Silberburgstraße 5
 72764 Reutlingen, Germany
 Phone +49 7121 146-0
 Fax +49 7121 146-250
 sales@wafios.de
 www.wafios.com

Precision Machinery for Wire and Tube