

Spring End Grinding Machines for Compression Springs



Series G

Series G

▼ Grinding room with particulate deflector



▼ Grinding table and spring length measuring device (in-process)



Our Accomplishments for your Benefit

- **Extensive standard equipment**
 - Standard machine includes all features needed to meet high demands on quality and output
 - Latest drive concept, all downfeed movements are carried out by servoaxes
 - Automatic dressing of grinding wheels
 - Spring length measuring device for guaranteeing a reliable production process
 - Laser sensors for an automatic compensation of grinding wheel wear
- **Programming system WPS 3.2 EasyWay**
 - Modern operating concept
 - Clearly structured user interface
 - Complete machine and process data control
- **Defined package of options**
 - Angular dressing of grinding wheels
 - Particulate deflector prevents grinding dust deposits
 - Interfaces for subsequent processes
 - Numerous features for process optimizations (iQs)

Design Features

Machine Structure

- Spring end grinding machine with grinding wheel of 450 mm or 660 mm diameter, for grinding both ends of compression springs simultaneously
- Universal single-plate machine version with loading plate diameters of 580 mm or 740 mm for down-feed and crush grinding operation
- Large-batch, double-plate machine version with 580 mm or 740 mm loading plate diameter for down-feed operation
- Grinding table with highly wear-resistant table plates
- Air showers for active cooling of springs during the grinding process
- Stable, fracture-proof protective shield
- Noise-insulating protective hood
- Interface for loading and unloading equipment



▲ G 450 Double-plate machine version

Powerful, Safe and Precise – WAFIOS Spring End Grinding Machines

Excellent combination of solid and reliable technology

WAFIOS spring end grinding machines feature an optimized scope of standard equipment and a defined number of options. Our spring end grinding machines are based on the engineering know-how WAFIOS AG acquired over the past decades. All of them are equipped with the high-end WPS 3.2 EasyWay programming system.

The G series reaches an optimal production capacity due to an infinitely adjustable peripheral speed of the grinding wheels between 35 and 50 m/s and an active cooling concept. The compensation of the grinding wheel wear is carried out automatically on the G series by two servomotors that are controlled by two laser sensors.

The extraction channel has been positioned tangentially to the grinding wheel and thus improves the extraction of grinding wheel dust. The availability of the machine is significantly increased by the optionally available particulate deflector with special alloy. Time- and labor-consuming cleaning processes are significantly reduced.

Quality

For more than 125 years, the name of WAFIOS has been synonymous with highest quality, safety standards, and technical innovations in the German machine manufacturing industry.

Reliability

Strict quality controls, state-of-the-art production systems, and many years of experience guarantee that your investment is safe in our hands. Our global service network ensures high availability of WAFIOS machinery.

Cost efficiency

High production output and a long service life will save money and shorten the amortization time of your investment.

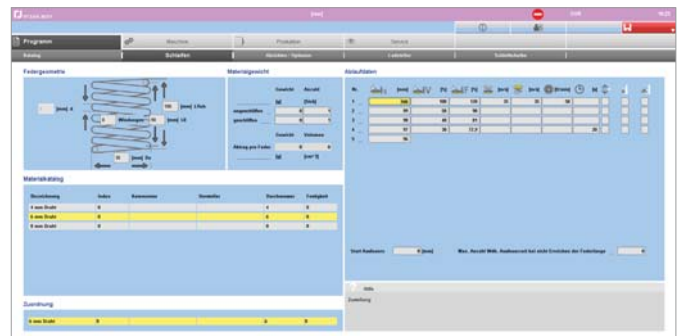

▲ New WAFIOS programming system WPS 3.2 EasyWay

▼ Automatic dressing unit

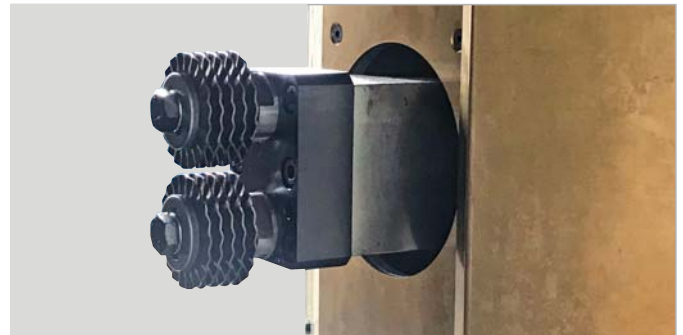

▲ Active cooling concept

Technical Data	G 450			G 660	
Wire Ø depending on spring geometry:	1.0 - 9.0 mm			2.0 - 12.0 mm	
Outer spring diameter:	100 mm max.			140 mm max.	
Spring length:	10 - max. 350 mm			10 - max. 350 mm	
Grinding wheels: (outer ø x height x bore hole ø)	450 x 80 x 100 mm			660 x 100 x 150 mm	
Peripheral speed of grinding wheels:	35 - 50 m/s (infinitely adjustable)			35 - 50 m/s (infinitely adjustable)	
Installed power of grinding spindles:	appr. 2 x 7.5 kW			appr. 2 x 11 kW	
Loading plate speed:	0.2 - 50 1/min (infinitely adjustable)			0.2 - 50 1/min (infinitely adjustable)	
Number of loading plates:	1	1	2	1	2
Loading plate diameter:	580 mm*	740 mm*	580 mm	740 mm	740 mm
Reception holes, loading plate:**	50 mm	60 mm	50 mm	60 mm	60 mm
Space requirement (without dust extraction) (lxwxh):	2.1 x 2.2 x 2.9 m	2.2 x 2.2 x 2.9 m	2.4 x 2.2 x 2.9 m	3.0 x 3.0 x 3.0 m	2.4 x 3.6 x 3.0 m
Weight: (without dust extraction)	appr. 3,600 kg	appr. 3,625 kg	appr. 4,500 kg	appr. 6,300 kg	appr. 7,200 kg

* Loading plate size can be selected, conversion not possible!

** Different diameters are available

▼ G 450 Single-plate Ø 580 mm

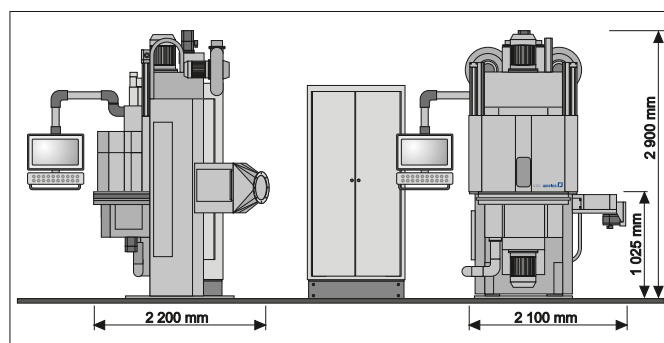

WAFIOS AG

Silberburgstraße 5
72764 Reutlingen, Germany
Phone +49 7121 146 - 0
Fax +49 7121 491209
sales@wafios.de
www.wafios.com

Precision Machinery for Wire and Tube