

# Wire Straightening and Cutting Machine for the Production of Straightened Rods Made of Round Wire

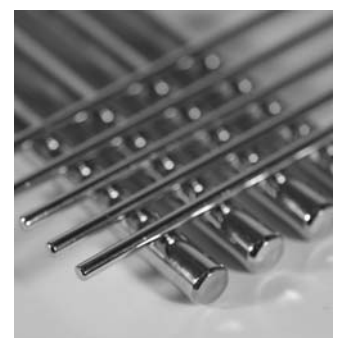

R 45

# R 45

▼ Infeed with straightening unit



▼ Stationary cutting unit

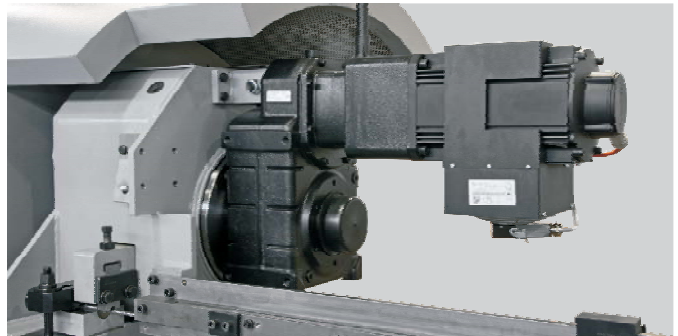

## Our Accomplishments for your Benefit

- New cutting unit for directly attached constructions with rod ejection on one or both sides
- More powerful while offering even more operating convenience
- Minimized set-up times
- Optimized and language-neutral operator guidance
- Several partial use of the tools of previous models
- Improved working conditions due to service instructions, electronically stored operating instructions

## Design Features

- New design combined with reliable technology
- Optimized feed and rotor technology
- Reduced noise emission due to the use of state-of-the-art materials
- Comfortable and language-neutral operation via SIEMENS Comfort panel
- Expanded attachment concept by directly attached construction with rod ejection on both sides (option)
- Chamfering (option)
- Optimum protection against soiling due to encapsulation of feed modules and rotor, channel for collecting lubricants and dirt, optional extraction unit
- Room for optional test probes in combination with measuring wheel
- Creative solutions for storing tools and operating tools
- Optionally spinner with servomotor adjustment

## Operation

- Reduced set-up times due to ergonomic access to all tools
- User-friendly color Touch Screen with masks e. g. ROD EASY mask: A selection of fixed wire diameter and wire type is stored. The values for the straightening ratio and the pressure of the feed rollers are applied automatically. In addition, the Operator can store their own types of wire.

▼ Measuring wheel



# Quality, Reliability and Efficiency – WAFIOS Straightening and Cutting-Off Machines

## New Definition of Productivity

WAFIOS R machines have been designed for the production of straightened and cut-off rods. They provide new technical solutions for increasing your output and optimizing costs.

The standard equipment of these machines includes 4 drives. As an option, the machines can be fitted with an additional push roller pair and a straightening system with a larger spacing to use the machines also in the larger diameter range.

Further options are compact rotors and a freely selectable number of cuts to increase the output, spray oil device, inserts for minimizing length tolerances as well as different extension versions for increasing the machines efficiency.

Moreover, tools and devices for processing profiles are also available if required.



▲ Tilting station

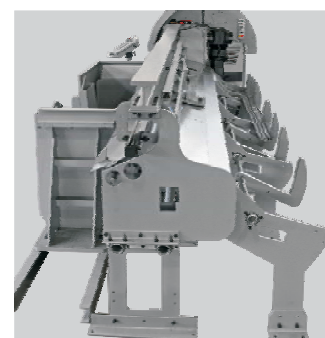

▲ Anbau für beidseitigen Stabausfall

## Quality

For more than 120 years the name WAFIOS has stood for the highest in terms of quality expectations, safety standards and technical innovation in German manufacturing systems engineering.

## Reliability

Strict quality controls, state-of-the-art production systems and many years of experience guarantee that your investment is in safe hands. Our global service network ensures high availability of WAFIOS machinery.

## Efficiency

High production output and a long service life will save money and shorten the amortization time of your investment.



▲ Graphical operator guidance

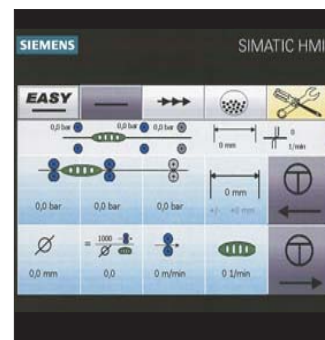

▲ Color touchscreen

Technical Data	R 45	R 45 ***
Feed speed (m/min)	5 - 180	5 - 180
Wire Ø (mm) **	(Standard) (B Version)	
400-800 (N/mm <sup>2</sup> )	3.0 - 10.0 4.0 - 12.0	4.0 - 10.0
800-1,200 (N/mm <sup>2</sup> )	4.0 - 9.0 5.0 - 10.0	5.0 - 9.0
1,200-1,600 (N/mm <sup>2</sup> )	4.0 - 8.0 5.0 - 9.0	5.0 - 8.0
Shortest cutting lengths (mm) with flat wire guide		
- with length measuring unit	100	100
- with release head	250	250
- with fixed stop	50 - 250	50 - 250
Max. cuts per minute	120	120
- with fixed stop (opt.)	220	220
Space requirement (l x w x h) mm without extension	2,810x1,400x1,780	2,810x1,400x1,780

\* Freely selectable number of cuts (option)

\*\* Cold-rolled reinforcing steel, measured across the ribs

\*\*\* Optionally spinner with servomotor adjustment

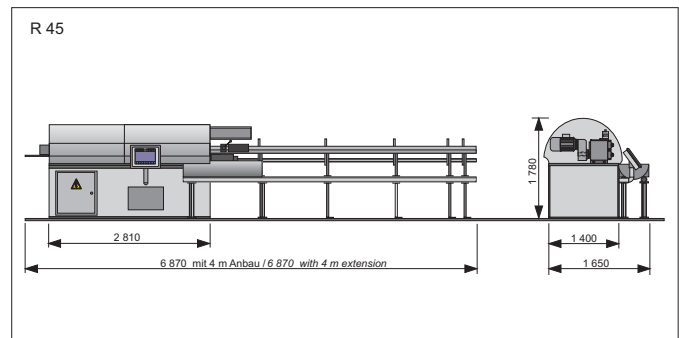
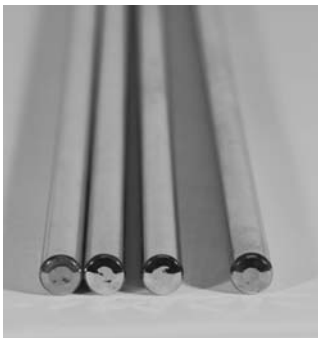

## WAFIOS AG

Silberburgstraße 5  
72764 Reutlingen, Germany  
Tel. +49 71 21 14 60  
Fax +49 71 21 49 12 09  
sales@wafios.de  
www.wafios.com

Precision Machinery for Wire and Tube