

CNC Multiple-head benders for the production of two- and three-dimensionally bent components

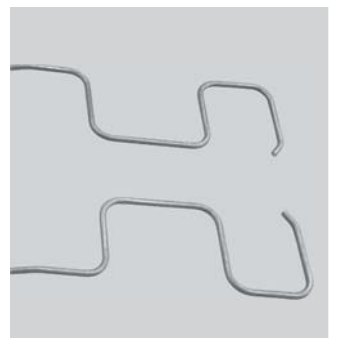

Series  
BT

# Series BT

▼ Straightening unit consisting of two pairs of feed rollers, rotary straightening unit and length measuring device

▼ Multiple-bending unit allows simultaneous bending on up to four bending heads

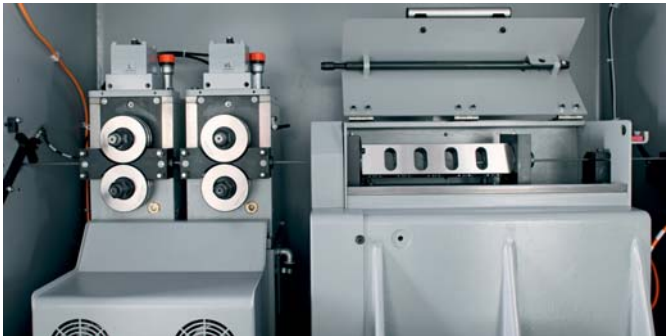

## Our accomplishment – Your benefit

- High output due to independently operating bending heads and new control concept WPS 3.2 EasyWay
- Highest process safety, further development of the successful and widely installed predecessor model BT 4
- High efficiency, especially when producing asymmetrical parts with many bends
- High flexibility, gripper holds part in a defined position ready for succeeding operations or integration in production sequences

## Features

### Machine structure

- Completely new, patented machine concept for an output many times higher than that of conventional CNC systems
- Powerful electronical system
- Highly dynamic straightening system
- Servo-electrically controlled cutting unit
- CNC-controlled wire feed and transport system
- Highly dynamic bending head drives
- 2 (BT 3.2/5.2) - 4 (BT 3.4) independently working bending units

### Operating range

- Maximum wire length: 2,000 mm (alternatively 3000 mm at BT 3.2 + BT 5.2)
- Minimum center length is 80 - 120 mm, depending on the geometry of the bent part (alternatively, there are also shorter lengths possible)
- Very large bending space due to the positioning unit's

## Software

- High-performance CNC machine control
- User-friendly and clear programming system WPS 3.2 EasyWay allows fast set-up and correction of geometry data and machine parameters
- Separate programming of bending units supports a rapid input of asymmetrical parts and facilitates correction
- *iQbend* - new control function for adjusting the bending sequence to the oscillation behavior of long and unstable bent parts

## Bending head

Equipped with an infinitely rotating bending and mandrel axis, allows the use of multi-radii bending tools and also the bending of closed loops. As the Z-axis movement is CNC-controlled, the output is increased and multi-stage tools can be employed. Additionally, there is the possibility to position the wire out of the bending head's center in order to be able to use bending tools type 3 and special bending tool versions.

# Powerful, safe and profitable – WAFIOS BT CNC multiple-head benders

## Precision made easy

Designed for the production of complex two- and three-dimensionally bent wire parts off the coil, the CNC multiple-head benders set the standard on the market when it comes to high output numbers.

The dynamically rotating straightening system guarantees increased precision with higher process safety.

The unique machine concept of the BT series, i.e. the special arrangement of bending heads and positioning units (advance feed) are protected by patents in many countries. Compared to conventional CNC machine concepts, the function principle of the BT 3.2 and 3.4 has increased output and precision many times.

The up to four independently operating bending heads with integrated positioning system make it easy for the operator to influence the geometry and programming of parts that must be true to gauge.



▲ Gripper with swivel arm in connection with bending tool (upper bending head)



▲ Gripper with swivel arm in connection with bending tool (lower bending head)

## Quality

For more than 120 years, the name of WAFIOS has been synonymous with highest quality, safety standards and technical innovations in the German machine manufacturing industry.

## Reliability

Strict quality controls, state-of-the-art production facilities and many years of experience guarantee high investment security. Our world-wide service network ensures a high availability of WAFIOS machinery.

## Efficiency

High production outputs and long machine service lives save money and shorten the payback period of your investment.

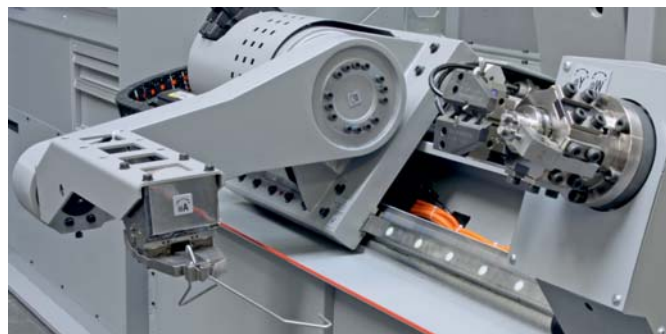

▲ Bent part in deposit or pick-up position, e.g. for following operations

Technical Data	BT 3.2 / BT 3.4	BT 5.2	
Wire dia. min.	2.0 mm	4.0 mm	
Wire dia. max.	< 600 N/mm <sup>2</sup> < 1200 N/mm <sup>2</sup> < 1900 N/mm <sup>2</sup>	6.5 mm 4.5 mm 4.0 mm (4.3 mm reinforced version)	10.0 mm 6.0 mm 5.0 mm
Feed speed max.	120 m/min	120 m/min	
Rod length min. - max.	200 - 2000 mm Option: 200 - 3000 mm (BT 3.2)	200 - 2000 mm Option: 200 - 3000 mm (BT 5.2)	
Distance towards center (Standard) With a special device	min. 80 - 120 mm min. 25 mm	min. 80 - 120 mm min. 35 mm	
Swivel angle of swivel arm max.	180°	180°	
Swivel angle of gripper	360°	360°	
Programming system	WPS 3.2 EasyWay	WPS 3.2 EasyWay	
Bending units	BT 3.2 = 2 BT 3.4 = 4	BT 5.2 = 2	
Bending moment	ca. 250 Nm	ca. 520 Nm	

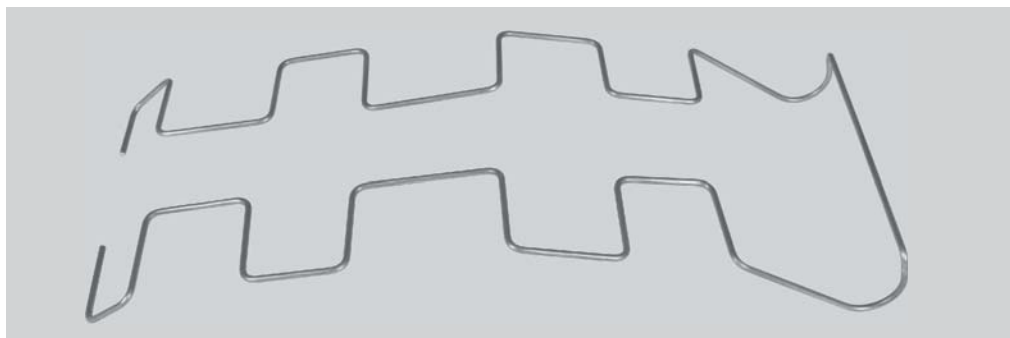
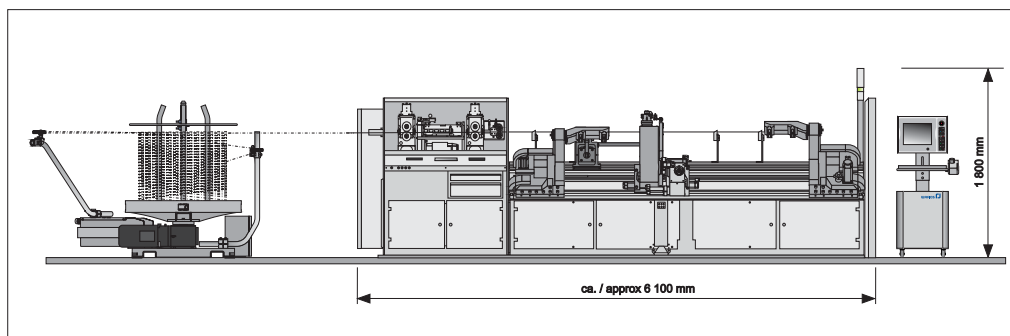

## WAFIOS AG

Silberburgstraße 5  
72764 Reutlingen, Germany  
Phone +49 7121 146 - 0  
Fax +49 7121 491209  
sales@wafios.de  
www.wafios.com

Precision Machinery for Wire and Tube