

# Multi-Radii Tool for Wire Bending Machine BM 60 with Positioning Aid

An approximately 15% smaller multi-radii bending tool could be created for the wire bending machine BM 60 by an optimization of bending points. As the bending clearance is increased, more flexible application possibilities are the result. The positioning aid supports the operator in correctly installing tools and thus reduces the risk of tool collisions.

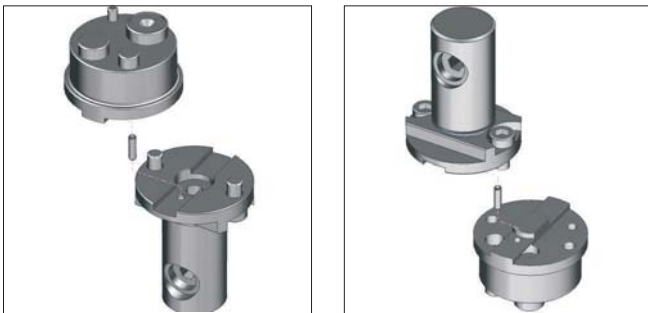

▲ Positioning aid

## Your benefit

- Larger bending clearance by a 15% smaller bending mandrel holder and fewer bending mandrels installed.
- Shorter leg lengths and larger bending angles are possible without having to reposition the bending tool.
- Longer tool life due to high-quality surface treatment.
- Coiling of shorter legs is possible at rear roller.
- Positioning aid supports the correct installation of tools (prevention of tool collisions) (BM 60 up to wire Ø 7mm)
- Already existing tool holding fixtures can be used by simple adjustment (boring) or removal of the positioning pin.



▲ Multi-radii tool BM 60

## Contact:

E-Mail: [Tools@wafios.de](mailto:Tools@wafios.de)

Phone: +49 (0)7121 / 146 1816

Fax: +49 (0)7121 / 146 202



Services