

Multi Bending Tool with ToolFix – MBT

Only for machines with a B axis

Bending Tool

An approximately 15% smaller multi-radii bending tool could be designed by optimizing the bending points. The smaller bending tool increases the bending clearance which makes application possibilities more flexible. Due to the nitrided surface of the bending mandrel holder, the coiling roller does not get worn during coiling operations, increasing the tool life significantly.

The ToolFix positioning aid supports the operator in correctly installing tools and thus helps to reduce the risk of tool collisions.

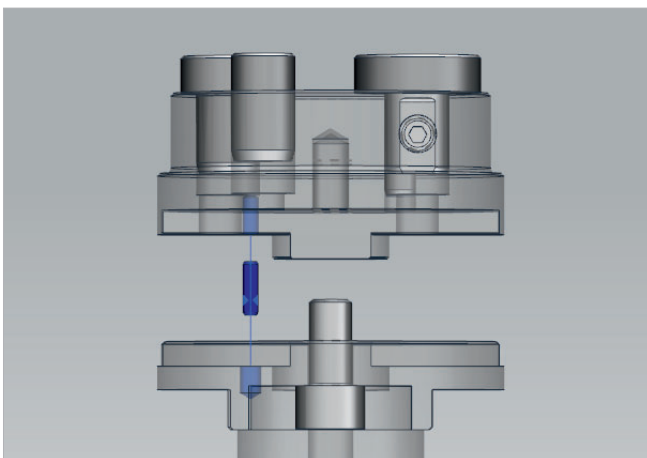
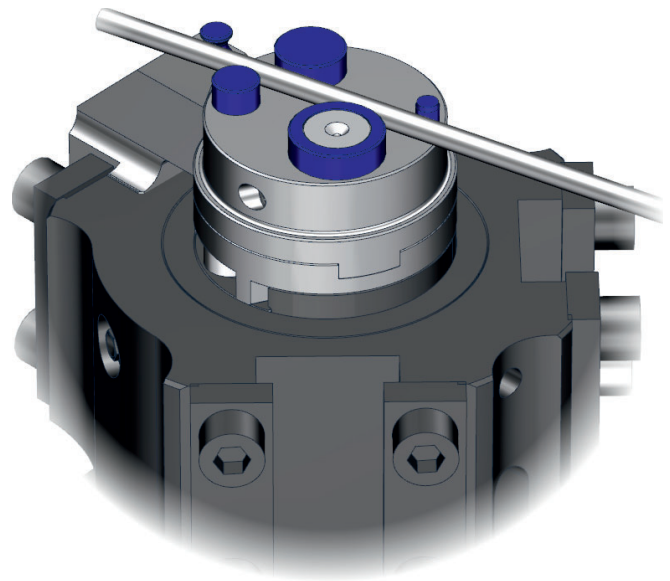

▲ ToolFix positioning aid

Machine Types:

- BM series
- BM 60 B axis option
- BMU series



Our Accomplishments for your Benefit

- Larger bending clearance by a 15% smaller bending mandrel holder and fewer bending mandrels installed
- Shorter leg lengths and larger bending angles are possible without having to reposition the bending tool
- Longer tool life due to high-quality surface treatment
- Coiling of shorter legs is possible at rear roller
- The ToolFix positioning aid supports the correct installation of tools (prevention of tool collisions) (BM 60 up to wire Ø 7 mm)

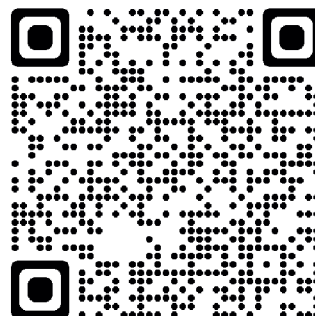

WAFIOS AG
Silberburgstraße 5
72764 Reutlingen, Germany

Phone: +49 7121 146-1816
Fax: +49 7121 146-250
tools@wafios.de, www.wafios.com

Precision Machinery for Wire and Tube